

Year 5 into Year 6 mathematics:

Reading scales

Key learning

Read and interpret scales on a range of measuring instruments. Compare readings on different scales, and when using different instruments.

Check that your child can:

- read a scale on a thermometer, ruler, tape measure, jug and weighing scale
- explain the units used when measuring
- read a scale when only parts of it are numbered
- create a scale to use to show measurements

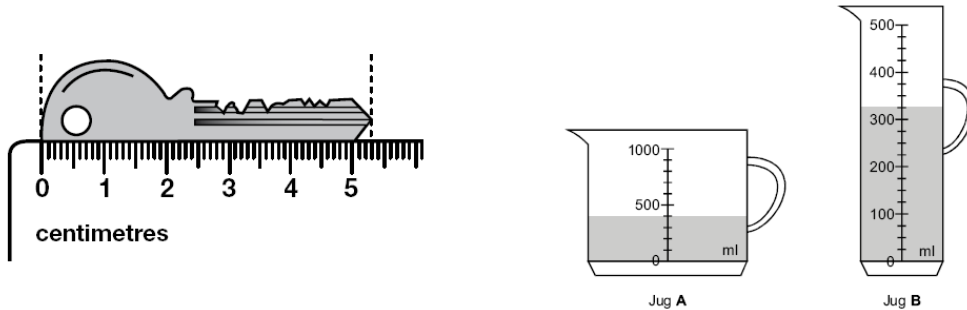

ICT Links

Use the internet to find more information about measures and scales. Explore Measuring Cylinder and Measuring Scales ITPs at

<http://www.standards.dfes.gov.uk/primaryframeworks/library/Mathematics/ICTResources/itps/>

Ask your child to read and interpret the scale, or add quantities to make a certain amount.

Notes for parents/carers

Children throughout primary school often find it difficult to read scales accurately. There are lots of opportunities to read scales in the home. Help your child to interpret scales in millimetres, centimetres and metres, millilitres and litres, grams and kilograms. Help them to read a measure when it falls between two unnumbered marks on a scale.

When measuring with your child, ask questions such as:

- How much does this weigh?
- What does each of these marks on the scale mean, why are some marks bigger than others?
- Look at Jug B. What units are we measuring in? What does 300 mean on this scale?
- How much more do you need to pour in to Jug B to make the amount up to half a litre?
- This scale reads 650g. What is that in kg?

Activities to carry out together:

- Each of you estimate how much an apple weighs then weigh it to see who was the more accurate.
- Find out whether all of the doorways in your house are the same height and width.
- Compare the capacities of different containers by filling them with water and then tipping the water into a measuring jug.
- Take a set of containers and put them in order of capacity by estimating, then measure to find out their accurate contents. Were there any surprises?
- Who is the most accurate at drawing a straight line of a given length? Can you draw it to the nearest millimetre?

“Let’s talk about maths”

Make use of opportunities to give your child practical experience of mathematics in the home and everyday life, such as:

- weighing;
- measuring;
- working out change;
- estimating;
- working out lengths of time.

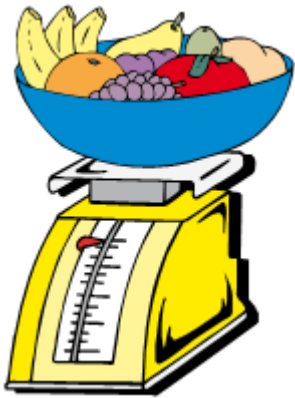

Listen to your child telling you about something they have learnt in mathematics – this may help them understand even better.

Example questions

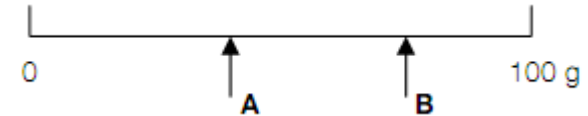

The arrows A and B represent two measures made using the scale. What are your estimates of these measures?



On the scale above, draw two arrows to show lengths of 35 cm and 13 cm.



One container holds 180 ml; the other holds 340 ml. Create a scale of your own and use it to show these two measures.